

i103 HD

8000000

PP

PP

PPVVVVVV

777

VVV

NNEENN

777

:

6777

VVVVVV(1)

6VV77

677

777

77y777

VVVVVVWV

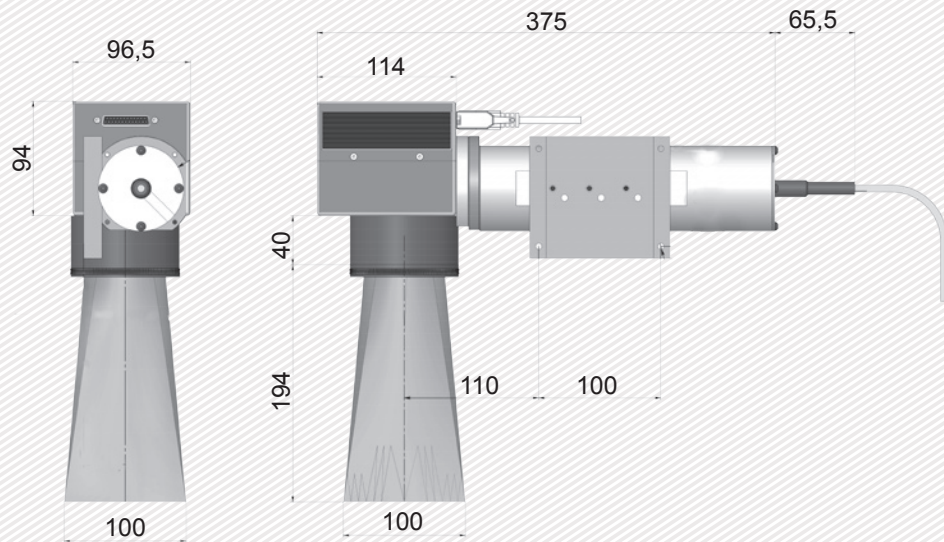

217521877



- + Control of digital axis (linear or rotating)
- + Laser driven by «SIC LASER» software
- + USB interface, Windows environment

- Operating method: pulsed (variable frequency)
- Consumption: 750 W
- Wavelength: 1 064 nm
- Average power: 20 W or 30 W (other, please contact us)
- Peak power: 10 kW
- Cooling: air only
- Warranty: 2 year

OPTIONS



Extraction and filtration systems

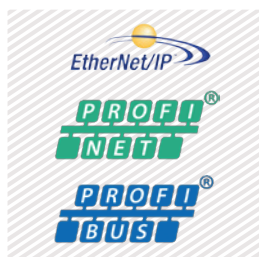

Communication cards

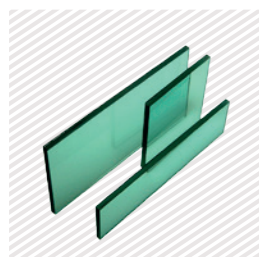

Protective glass



Integrated vision system

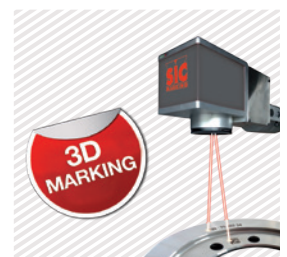

Multi-level marking